

PRE-STRESSED RIBBED SLAB

TT

GENERAL

SIA TMB Elements manufactures ribbed slabs with pre-stressed reinforcement with product name TT slabs in conformity with the standards LVS-EN 13224 "Precast concrete products – Ribbed floor elements" and LVS-EN 13369 "Common rules for precast concrete products".

The TT slabs are produced by using pre-stressed longitudinal reinforcement in the tensile zone and, if necessary, also in the compressive zone of the slab. Transverse reinforcement is used at least within the length of the anchor zone of the longitudinal reinforcement. The TT slab consists of an upper board and two longitudinal ribs. The standard width of the TT slab is 3,000 mm, height is between 400–1,000 mm with a spacing of 100 mm, the length is up to 24 m and weight is up to 30 tons. The width of the rib is selected according to the bearing capacity and fire resistance requirements. The standard widths of the ribs are 140, 160, 180, 240 and 300 mm.

Due to the small thickness (50 mm) of the upper board of the slab, a cast-in-place concrete topping has to be used for the division of load in the transverse direction and for the formation of a horizontal diaphragm of rigidity. The topping also enables to increase the bearing capacity and rigidity of the TT slab. The thickness of the topping in the middle of the slab should be at least 40 mm, the strength class of topping concrete shall be at least C25/30. The upper surface can be roughened in order to improve adhesion between the slab and the topping.

If necessary, openings and cut-outs can be made in TT-slabs and ribs (see section "Openings").

USAGE

TT-slabs are used for the construction of the load-bearing structures of ceilings and flat roofs.

The slabs are supported in accordance with the design scheme of a simple or cantilever beam. The approximate bearing capacity and camber graphs of TT slabs that function as simple beams are indicated in the section "Bearing capacity and camber graphs".

There is several advantages if precast-prestressed elements are used in construction:

- factorycontrolled conditions. Quality can be controlled and monitored much more easily;
- at production are used only certified raw materials;
- influence of weather at production is eliminated;
- significant savings in concrete and in reinforcement quantities due to pre-stress;
- accelerated curing reduce the time between casting of element and putting it into service;
- possible to produce slabs with a longer span than is practical with ordinary reinforced concrete;
- precast elements can be installed immediately. It results faster construction time.

T Y P E I N D I C A T I O N

TT-slab indication includes the marking of the slab, date of manufacturing, slab weight and registration number.

The slab marking consists of a letter-number combination, which indicates slab type, rib width and the sequential number of the slab in the design.

An example of slab marking: **TT 80-18-132**, where

TT 80 indicates the slab type;

18 stands for the rib width in cm;

132 is the sequential number of the slab in design.

Table 1.

Type indications of TT-slabs

Slab height (mm)	400	500	600	700	800	900	1000
Type	TT 40	TT 50	TT 60	TT 70	TT 80	TT 90	TT 100

An example of TT slab indication: **TT 80-18-133 11.12.09 19,3T1338**

This stands for a TT-slab with the height of 800 mm and rib width of 180 mm. The sequential number of the slab in design is 133 and the manufacturing date is 11.12.2009. The TT slab weight is 19.3 tons and the registration number is 1338.

F I R E R E S I S T A N C E

The fire resistance class of TT-slabs is determined according to standard LVS-EN 1992-1-1 Eurocode 2: Design of concrete structures - Part 1-2: General rules – Structural fire design.

The required fire resistance of TT-slabs is granted by the selection of the appropriate rib width and the concrete cover of reinforcing and pre-stressing steel. The fire resistance class is between R60–R120. A fire resistance class higher than R60 requires a thicker upper slab board.

C R O S S - S E C T I O N S A N D D E A D W E I G H T S

The cross-sections and dimensions of TT-slabs are indicated in Figures 1–2 and Tables 2–4.

Table 2.

Dead weights of TT-slabs

TT-slab height h (mm)	Dead weight (kN per meter)				
	Rib width (mm)				
	140	160	180	240	300
400	-	7,15	7,50	8,55	-
500	-	8,12	8,57	9,92	-
600	8,57	9,12	9,67	11,32	-
700	9,51	10,16	10,81	12,76	-
800	10,49	11,24	11,99	14,24	16,49
900	-	-	13,21	15,76	18,31
1000	-	-	14,47	17,32	20,17

Figure 1.

Cross-section of a TT-slab
(Mould 1)

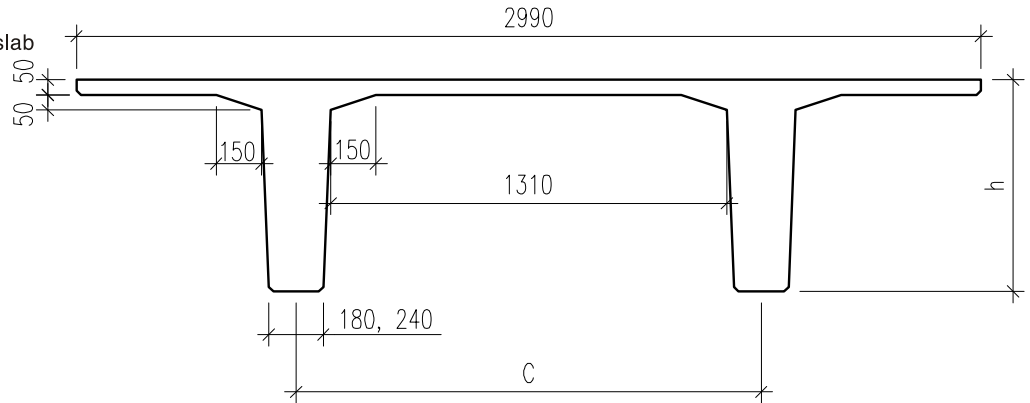

Table 3.

Spacing between rib
centres of TT-slabs
(Mould 1)

TT-slab height h (mm)	Spacing between rib centres C (mm)			
	Rib width (mm)			
	140	160	180	240
400	-	1494	1514	1574
500	-	1502	1522	1582
600	1490	1510	1530	1590
700	1498	1518	1538	1598
800	1506	1526	1546	1606

Figure 2.

Cross-section of a
TT-slab
(Mould 2)

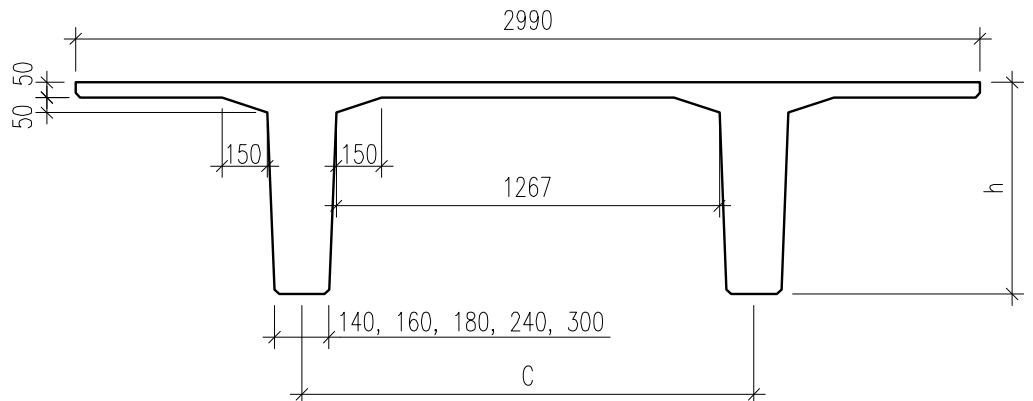

Table 4.

Distances between the rib
centres of TT-slabs
(Mould 2)

TT-slab height h (mm)	Spacing between rib centres C (mm)				
	Rib width (mm)				
	140	160	180	240	300
400	-	1451	1471	1531	-
500	-	1459	1479	1539	-
600	1447	1467	1487	1547	-
700	1455	1475	1495	1555	-
800	1463	1483	1503	1563	1623
900	-	-	1511	1571	1631
1000	-	-	1519	1579	1639

B E A R I N G C A P A C I T Y A N D C A M B E R G R A P H S

The bearing capacity and camber graphs of TT-slabs that function as simple beams can be used when determining the initial cross-section of the slab for dwelling houses, public or office buildings, traffic surfaces and squares (except warehouses etc). The graphs are drawn according to the following standards:

- LVS-EN 1990 Eurocode - Basis of structural design;
- LVS-EN 1991-1-1 Eurocode 1: Actions on structures – Part 1-1: General actions – Densities, self-weight, imposed loads on buildings;
- LVS-EN 1991-1-2 Eurocode 1: Actions on structures – Part 1-2: General actions – Actions on structures exposed to fire;
- LVS 1992-1-3 Design of concrete structures - Part 1-3: Common rules for design of forced concrete structures.

The graphs are valid on following conditions:

- the standard value of bearing capacity does not include the dead weight of the element;
- **the proportion of dead and live load of the standard value of the bearing capacity is 50% and 50% accordingly;**
- the combination factors of variable load are $\gamma_0 = 0.7$; $\gamma_1 = 0.7$; $\gamma_2 = 0.6$ (in case of different combination factors, control calculations must be used);
- the slabs are supported by steady supports;
- the supported length of the slab when designed is ≥ 100 mm;
- the serviceability limit sag of a slab is $\text{span}/250$
- the camber graphs apply in case the slabs are manufactured one month ago, they are unloaded and have the maximum pre-stressed reinforcement;
- the concrete strength class of the slabs is C40/50;
- a 12.5 mm strand (strength class 1860/1635, relaxation class 2) is used as pre-stressed reinforcement;
- the maximum number of strands in slab ribs is indicated in the graphs;
- the maximum initial pre-stress of the strands is 1,300 MPa.

Figure 3. Bearing capacity and camber graphs for TT-slabs with 140 mm ribs

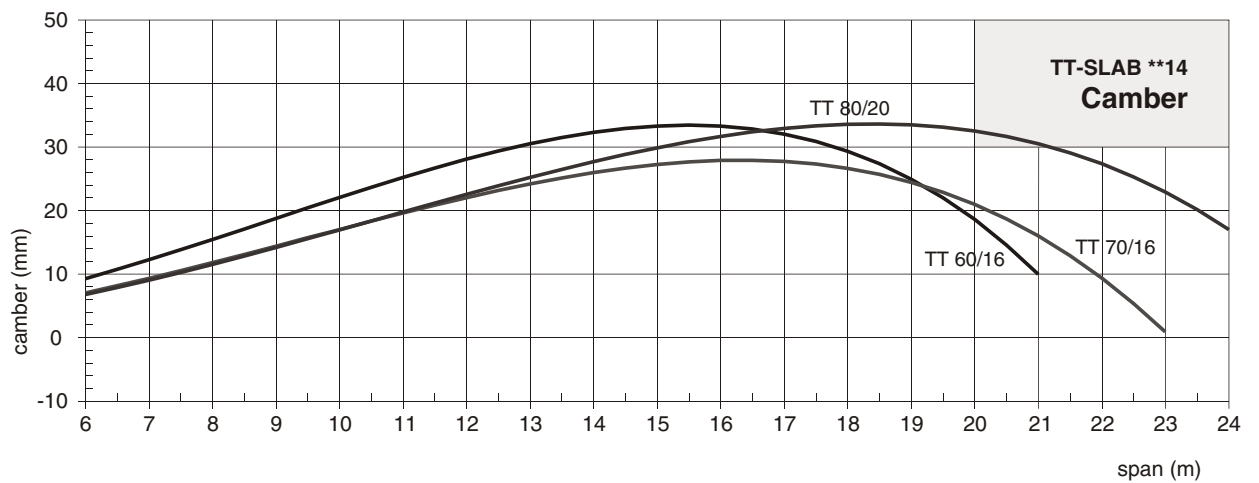
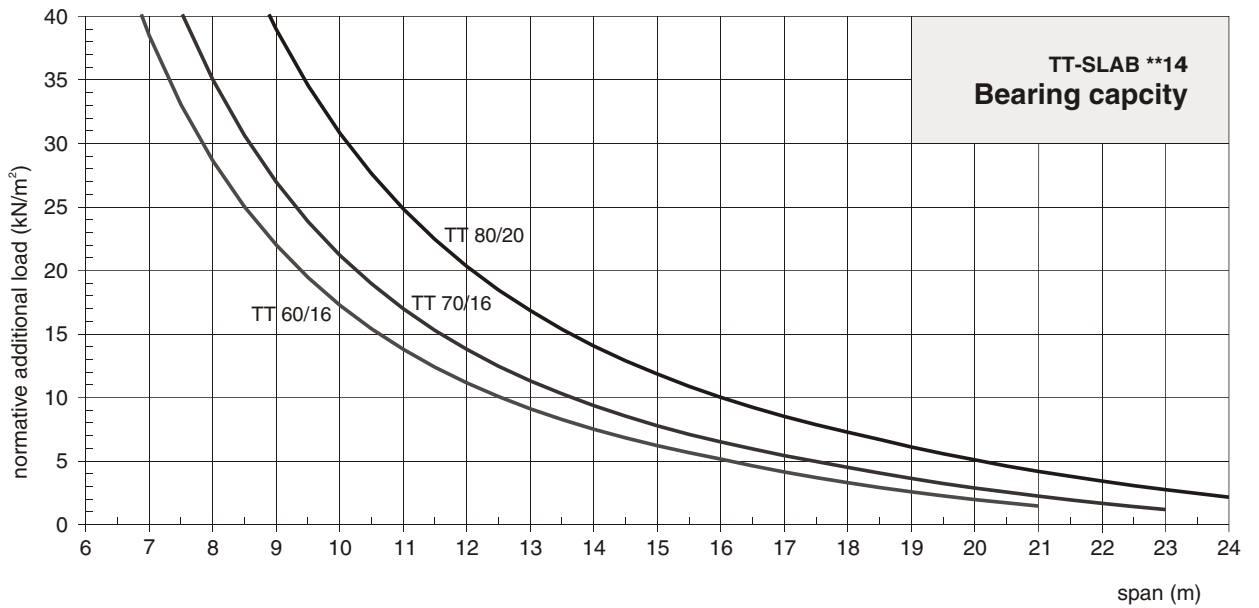

Figure 4. Bearing capacity and camber graphs
for TT-slabs with 160 mm ribs

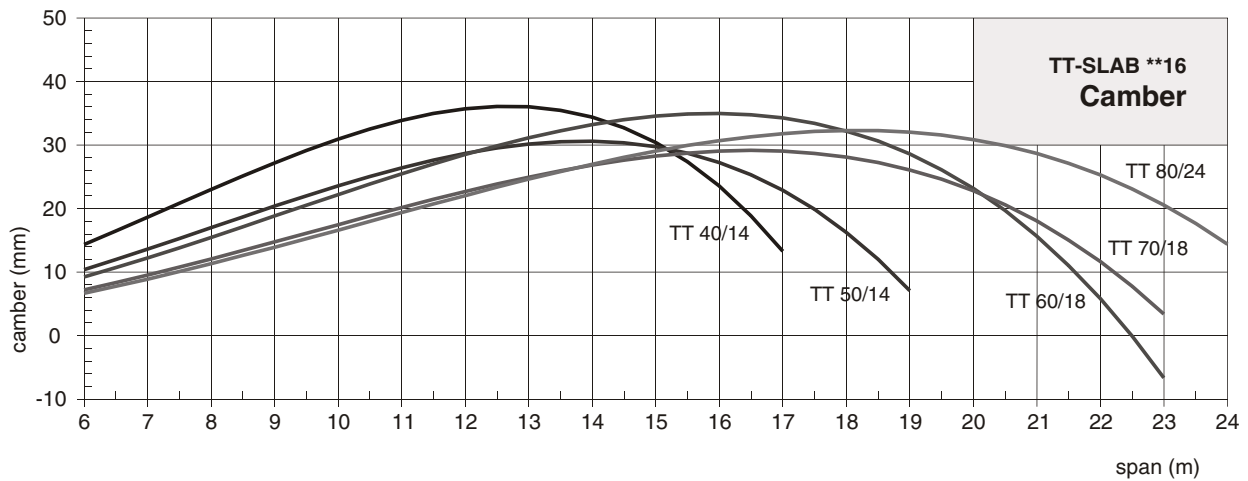
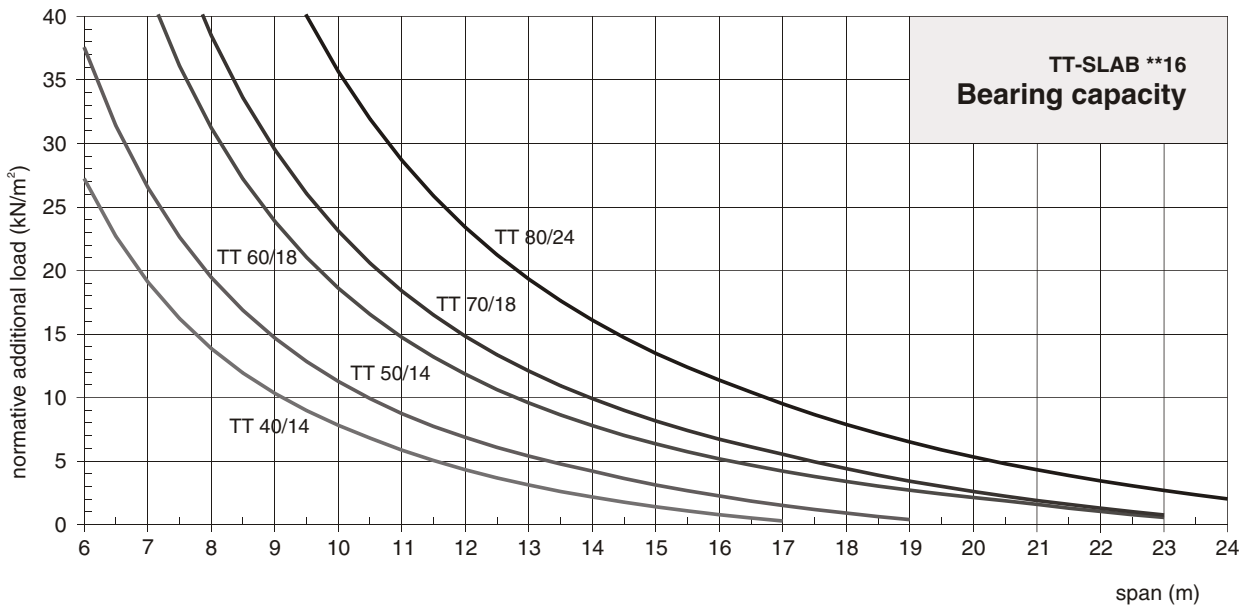

Figure 5. Bearing capacity and camber graphs for TT-slabs with 180 mm ribs

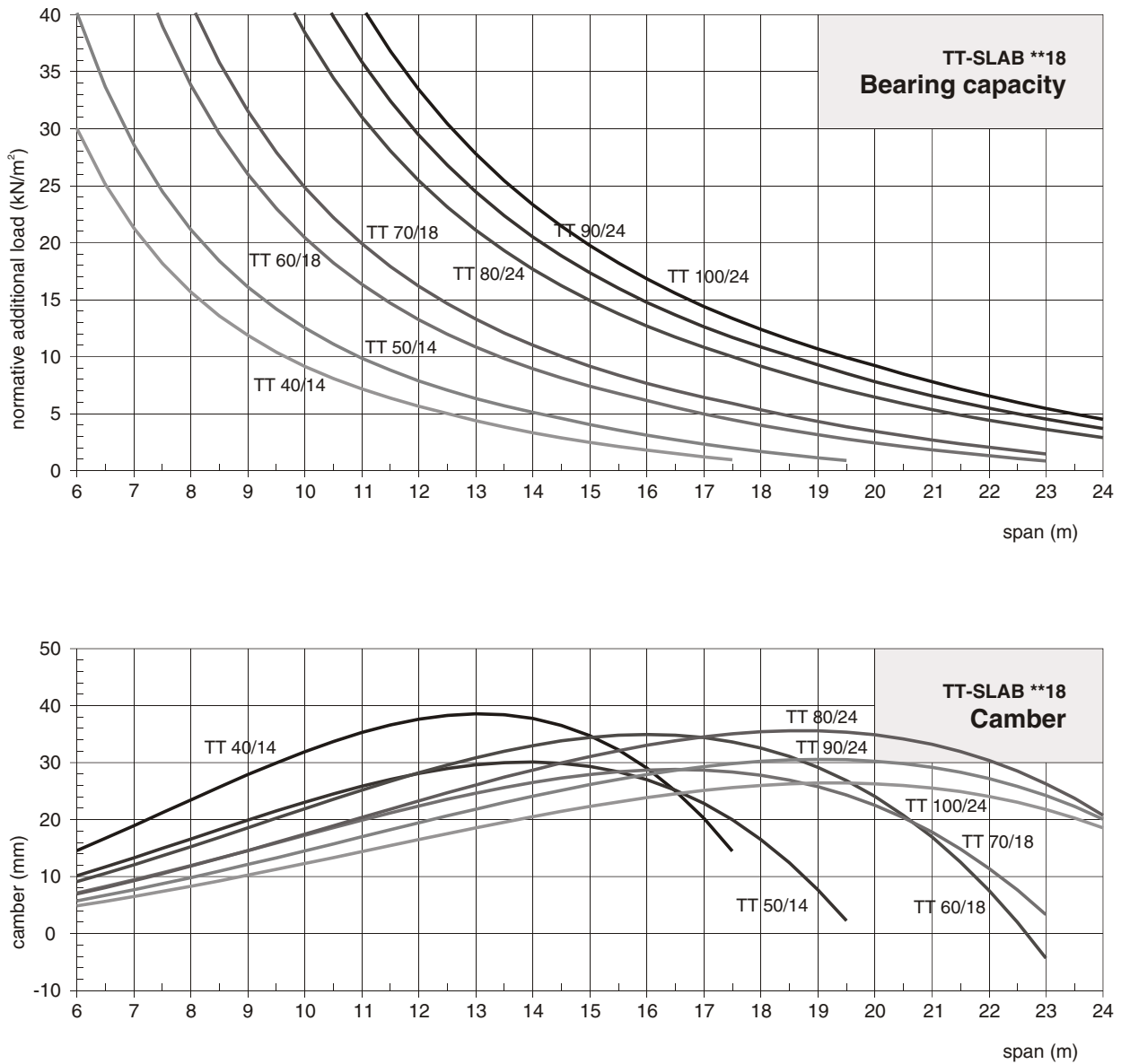

Figure 6. Bearing capacity and camber graphs for TT-slabs with 240 mm ribs

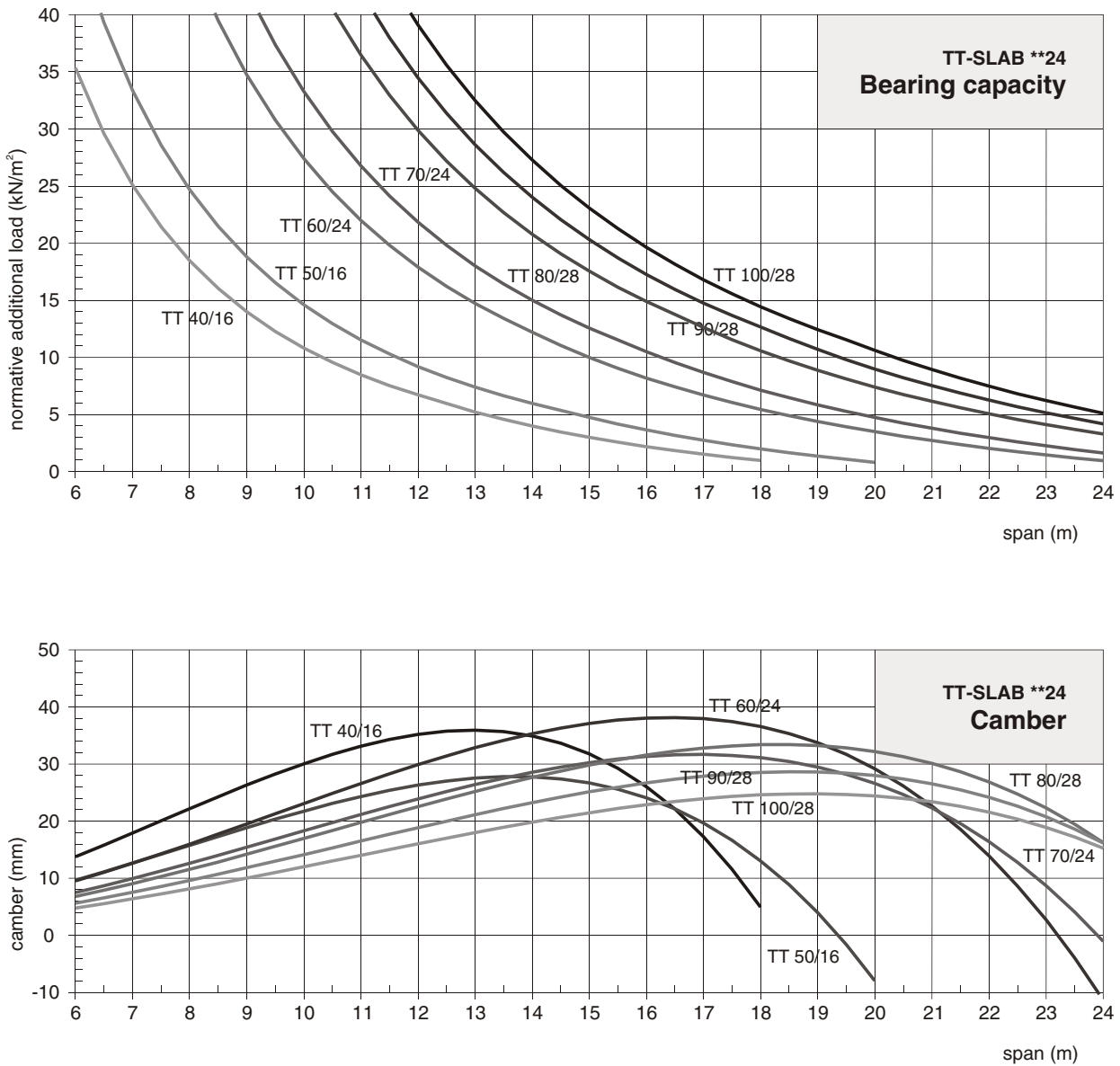
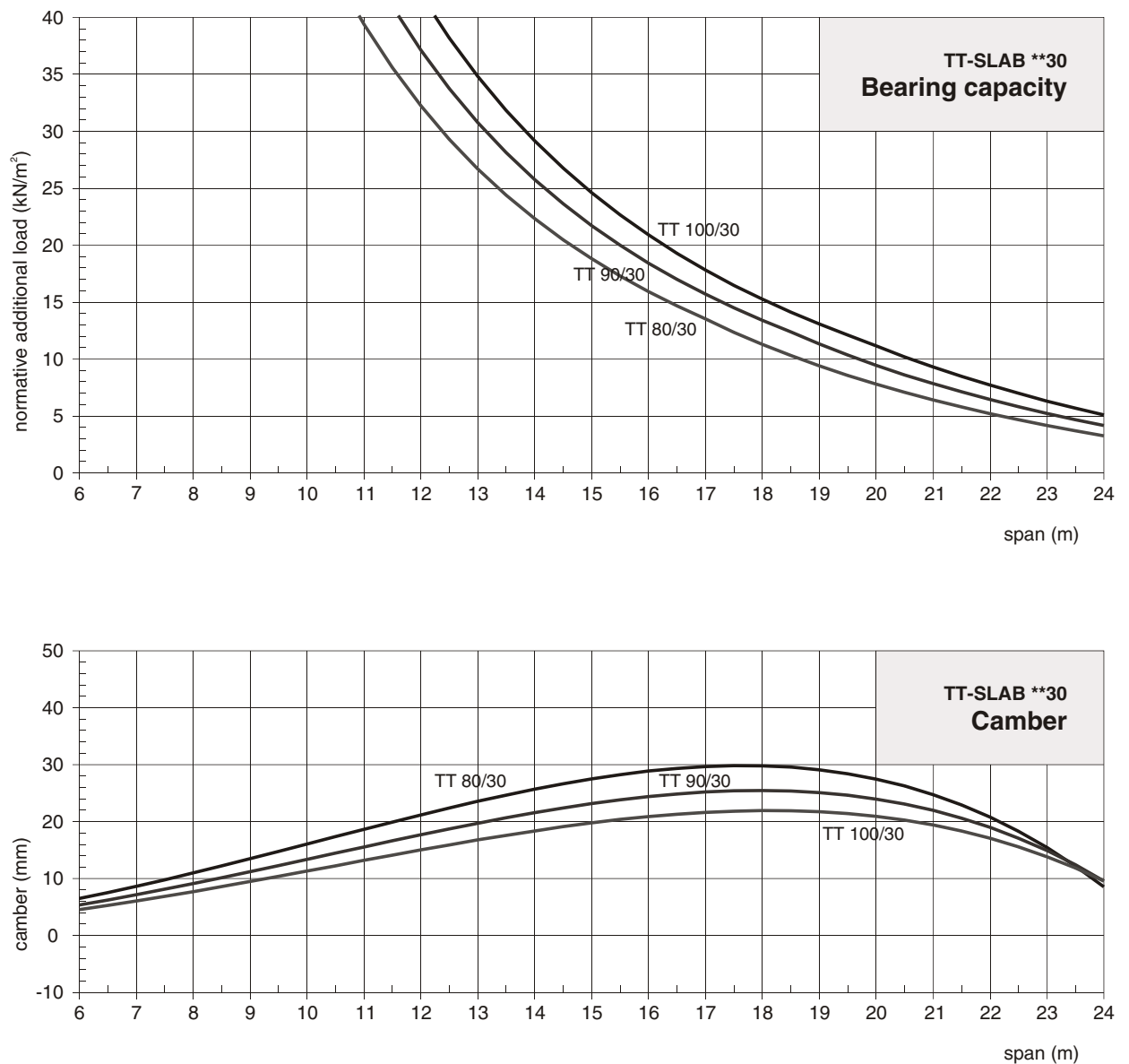

Figure 7. Bearing capacity and camber graphs
for TT-slabs with 300 mm ribs



**BEARING CAPACITY GRAPHS
FOR FLAT ROOF SLABS**

The bearing capacity graphs of TT-slabs that function as simple beams can be used when determining the initial cross-section of slabs when constructing an insulated flat roof without any additional sloping layers.

The graphs are valid on the following conditions:

- the standard value of bearing capacity does not include the dead weight of the panel and the surface layers of the roof;
- the standard weight of the roof surface layer is supposed to be 0.5 kN/m²;
- the combination factors of snow weight is $\gamma_0=0,5$; $\gamma_1=0,2$; $\gamma_2=0$;
- the slabs are supported by steady supports;
- the supported length of the slab when designed is 100 mm;
- the serviceability limit sag of a slab is: span/250;
- the concrete strength class of the slabs is C40/50;
- a 12.5 mm strand (strength class 1860/1635, relaxation class 2) is used as pre-stressed reinforcement;
- the maximum number of strands in slab ribs is indicated in the graphs;
- the maximum initial pre-stress of the strands is 1,300 MPa.

Figure 8.

The maximum snow load of flat roofs made of TT-slabs with 160 mm ribs (normative additional permanent load $g_k=0,5 \text{ kN/m}^2$)

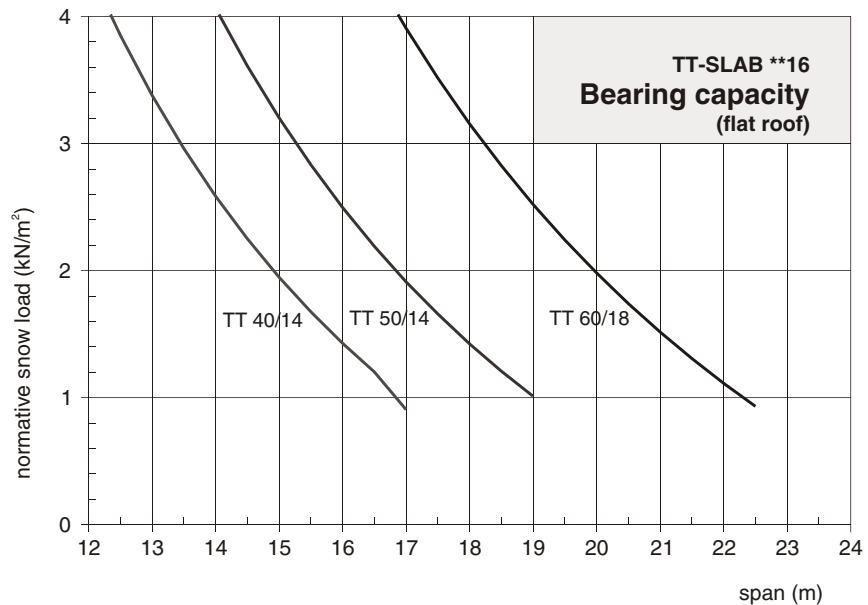

Figure 9.

The maximum snow load of flat roofs made of TT-slabs with **180 mm ribs** (normative additional permanent load $g_k=0,5 \text{ kN/m}^2$)

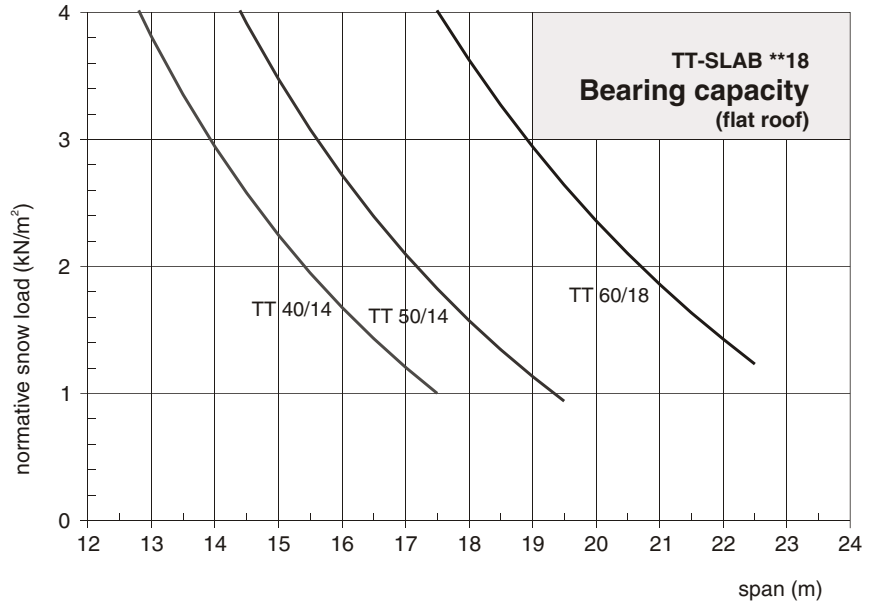
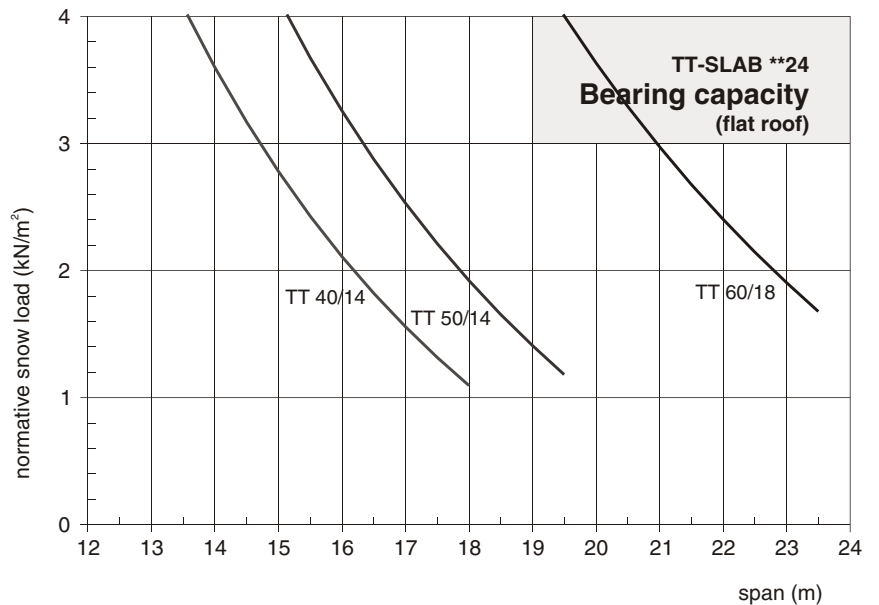

Figure 10.

The maximal snow load of flat roofs made of TT-slabs with **240 mm ribs** (normative additional permanent load $g_k=0,5 \text{ kN/m}^2$)



O P E N I N G S

Openings can be made in the slab upper board in the points indicated in Figure 11.

Into the rib of the TT slab, not closer to the support than one fourth of the span, openings can be made with the side dimension of not over half of the TT slab height. The centre of the opening should coincide with the centre of the cross-section of the TT slab.

Cuts can be made into the ribs at slab ends at 1/3 of the length of the TT slab height in order to reduce the total height of a ceiling structure.

Figure 11.

Dimensions and locations of openings made into TT-slabs already in the factory

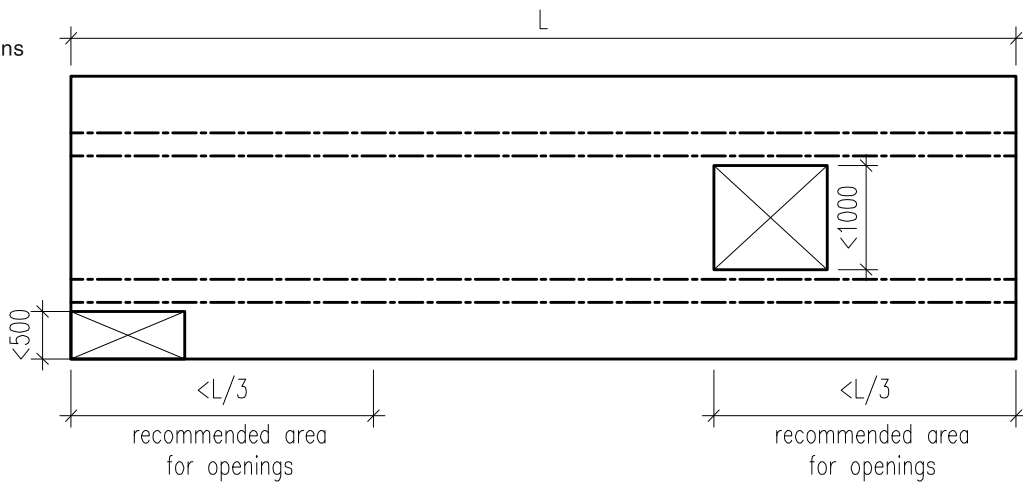

M A T E R I A L S

Concrete for TT slabs complies to the requirements of standards LVS EN 206-1 "Concrete - Specification, performance, production and conformity" and LVS 156-1 "Concrete - National annex of Latvian standard to European standard EN 206-1 - Part 1: Requirements for classification and attestation of conformity".

For TT slabs are used **normal-weight concrete** with:

- the strength class of at least C40/50.

Reinforcing steel. Reinforcement shall conform to standard LVS-EN 10080 "Steel for the reinforcement of concrete – Weldable reinforcing steel – General";

Prestressing strands shall conform to standard prEN 10138-3 "Pre-stressing steels. Part 3: Strand".

P R O D U C T I O N

TT-slabs are produced on heated pre-stressing steel mould with an optional length of up to 24 m by using steel and veneer formwork. The slab board is reinforced with a welded fabric and lateral reinforcement at the ends of slab board. The ribs are reinforced in the longitudinal direction with pre-stressed reinforcement and in the transverse direction with stirrups at least at the length of the anchor zone of the longitudinal reinforcement. Depending on the exploitation load, the ribs at slab ends can be reinforced additionally with horizontal U-shaped bars. A 12.5 mm strand is used as pre-stressed reinforcement. The initial pre-stress of the strand does not exceed 1,300 N/mm². The maximum strength per one rib of the mould must not exceed 2,100 kN.

The fresh concrete is compacted by vibration.

The concrete strength ($f_{cm,p}$) at transfer of the pre-stressing force is at least 25 N/mm². The concrete strength of the slab at the delivery is at least 70% of the strength class of concrete.

The bottom surface of the slabs is formed against a steel mould, it is smooth and does not require any additional surface treatment before applying the finishing coat. The upper surface can either be smooth or roughened.

Q U A L I T Y

Because precast concrete elements are produced in a controlled environment, they exhibit high quality and uniformity.

The quality of TT slabs is based on Factory production control (FPC) including frequent inspection of the testing and measuring equipment, storage and production equipment, raw materials, production processes and finished product.

Our FPC system is certified.

PRODUCTION TOLERANCES

TT-slabs production tolerances (table 5) correspond to the following values of the production standards LVS-EN 13224 Precast concrete products – Ribbed floor elements and LVS-EN 13369 Common rules for precast concrete products, unless the technical drawings do not state otherwise.

Table 5.

Production tolerances

Measurement	Tolerance (mm)
Length L	+/- 20
Board thickness h_b	+ 10; - 5
Board width b	+/- 30
Slab height h ¹⁾ , rib width b_w	
$b_w = 180$	+ 10; - 5
$b_w = 240$	+ 12; - 7
$h = 400$	+/- 15
$h = 600$	+/- 17
$h = 800$	+/- 18
Skewness, p	+/- 15
Lateral bow, a	+/- 15 või +/- L/650 (the bigger one)
Angular deviation of ribs,	+/- 22,5
Planarity	+/- 15

¹⁾ the intermediate values of h are linearly interpolated

The nominal measurement of the concrete cover of the reinforcement must equal at least the minimal thickness of the concrete cover according to its durability plus minimal tolerance limit.

The symbols used in the table of production tolerances are explained in Figure 1.

Figure 12.

Symbols in tolerance table

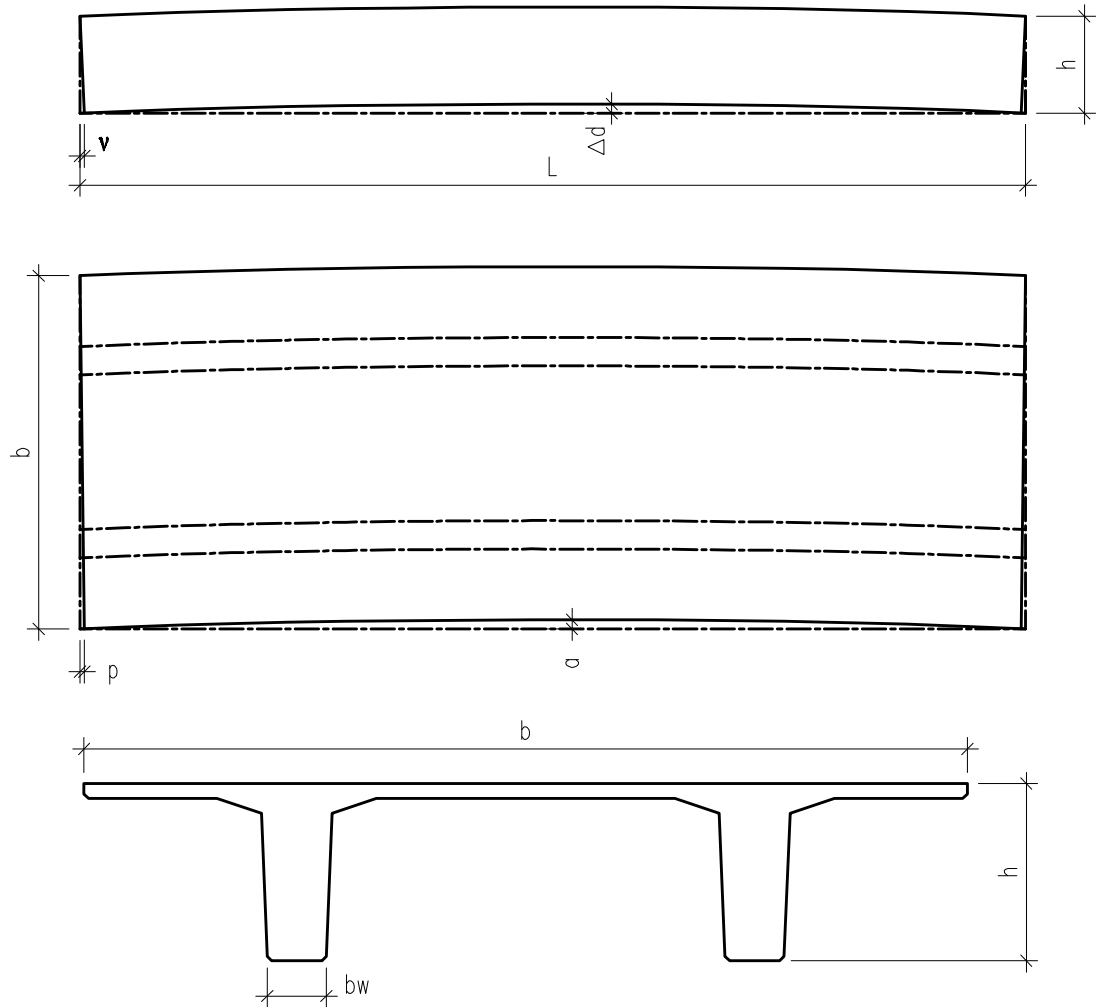

STORAGE AND TRANSPORTATION

TT-slabs are stored and transported in up to 1.5 m high piles. The TT slabs are stored on 100x100 mm bearers that are placed on a compact horizontal ground. The TT slabs are supported at the ends, unless otherwise indicated in the technical drawings. Intermediate bearers, which are thicker than the length of the hoisting eyes, are placed between the slab rows. The intermediate bearers must remain above one another. During transportation, the slabs must be secured on the means of transportation in order to prevent them from moving.

ASSEMBLY

During the assembly, the TT slab is rested on a 8–10 mm neoprene mat (Figure 13) or on a steel support at full length. The nominal support length of the TT slab is at least 100 mm. One of the possible assemblies is shown in Figure 14. A selection of longitudinal connections of TT slabs is shown in Figure 15.

Figure 13.

Connection joint of a TT-slab on L-beams or inverted T-beams

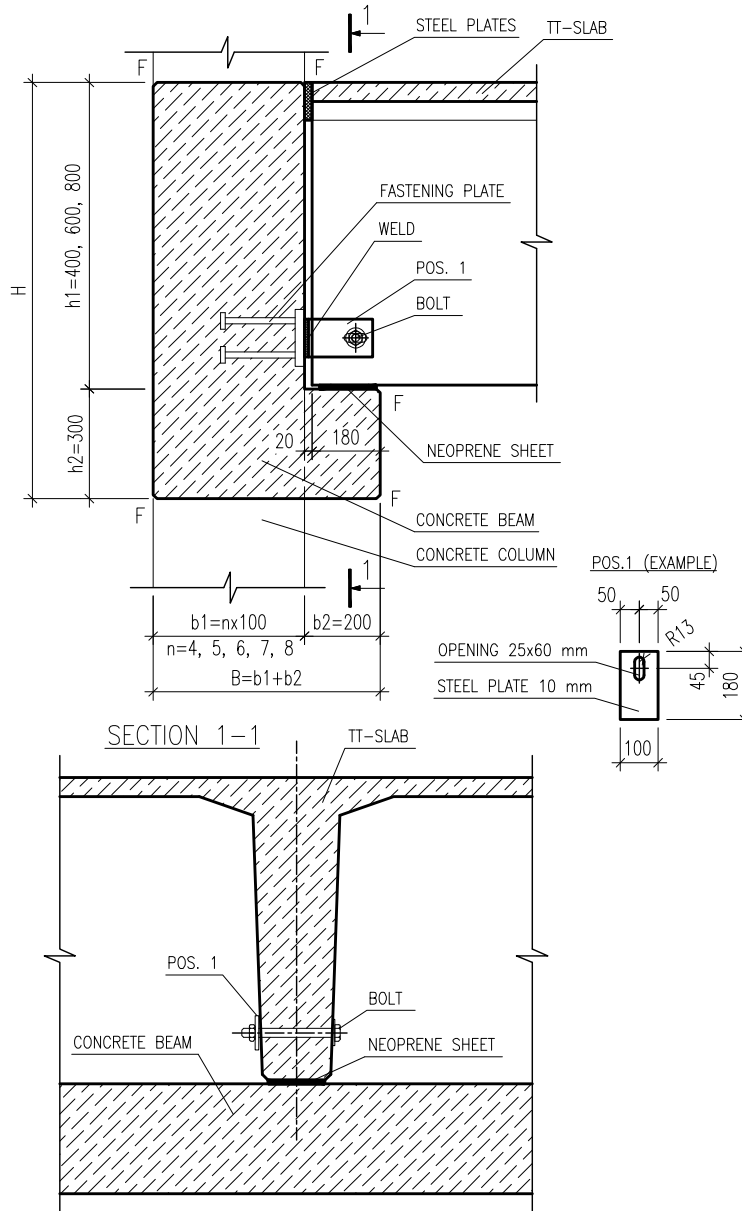

Figure 14.

Connection joint of a
TT-slab on a rectangular
beam

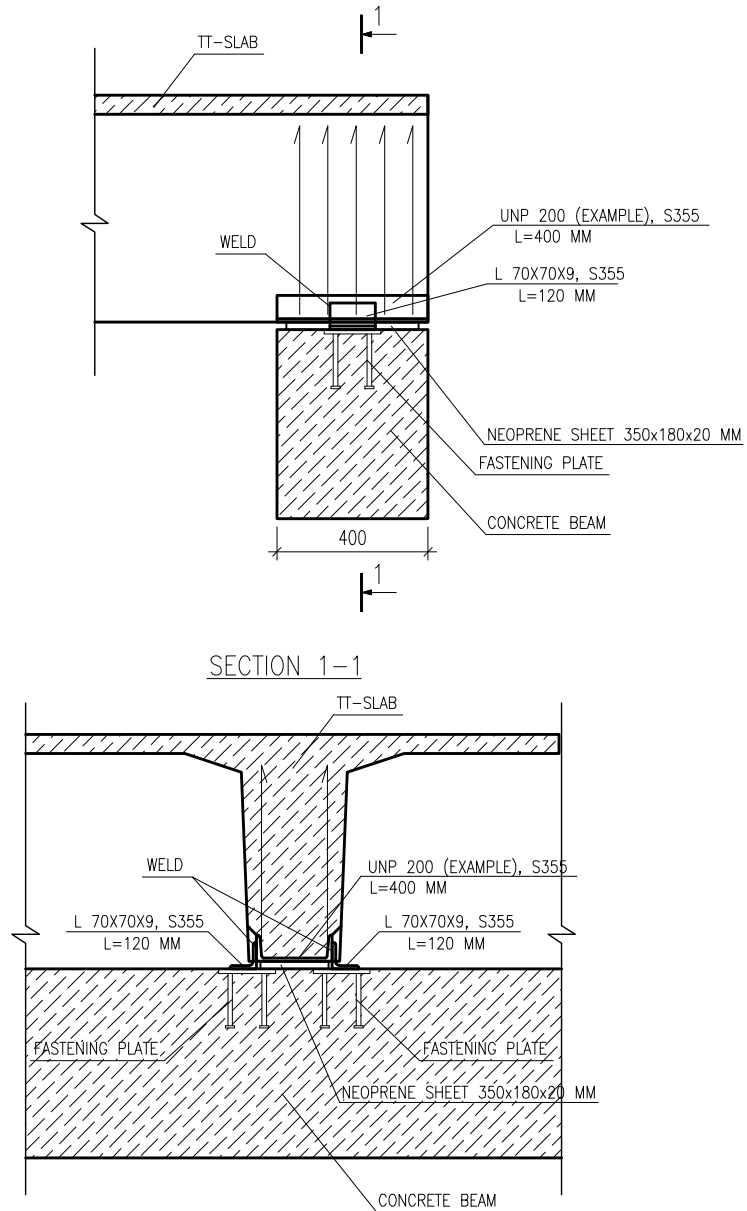

Figure 15.

Adjacent assembly of TT-slabs

